

metapan cTM - series

OPEN CELL METAL CEILING SYSTEM



TECHNICAL DATA SHEET BPIR - CLASS 1



metapan c™ - series

Open Cell Metal Ceiling System

Technical Data Sheet - BPIR Class 1

MetaPan C™-series ceiling system applies an open cell ceiling design. Each 600 x 600 mm panel is an assembly of interlinked folded alloy profiles that interconnect to main and cross runner support sections on site.

Panels may be demounted for access to plenum services.

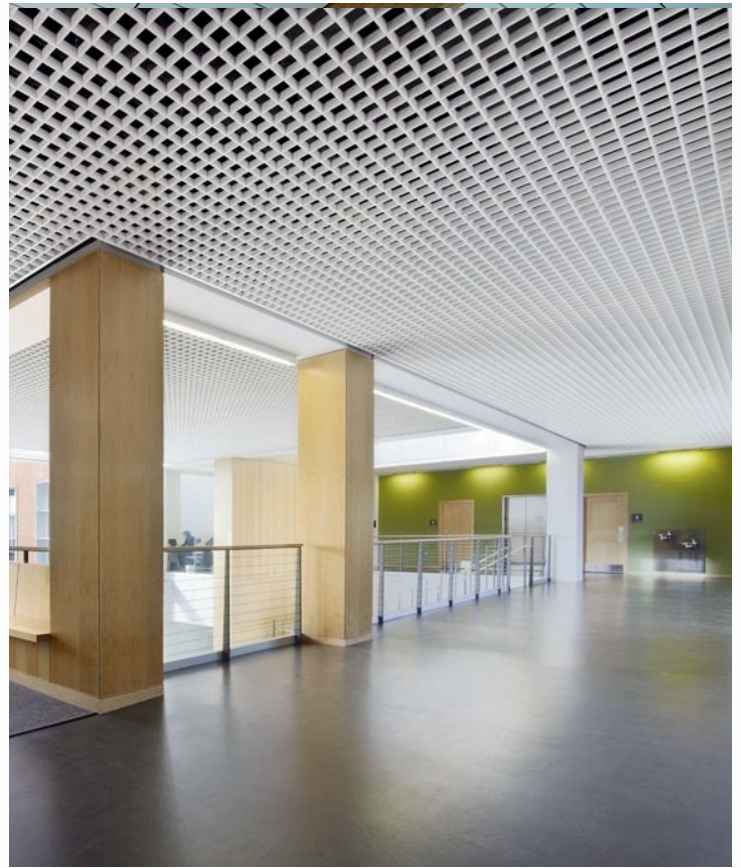

Application

MetaPan C™ is ideal for open office, retail, commercial interiors, transport facilities etc that require a long life open cell ceiling. It is also ideal for security applications due the open areas between the cell elements. Not for exteriors.

Composition

Manufactured from aluminium alloy strips, press formed, polyester powder coated. Additional absorber material can be added behind to meet acoustical requirements, please consult Asona's technical sales team.

Features & Benefits

- Modern contemporary aesthetic.
- High open area allows for sprinklers to be mounted in the plenum to reduce visual clutter. Permits visual inspection of plenum void for security sensitive spaces.
- Durable long life coated aluminium.
- Wide range of cell height and open area options.
- Available in white and a range of standard colours.
- Non-combustible metal construction.
- Fire Group Rating 1-S.
- Accessible for maintenance.

Model #	Cell Dimension
MPC-50	50 x 50 mm
MPC-75	75 x 75 mm
MPC-100	100 x 100 mm
MPC-150	150 x 150 mm
MPC-200	200 x 200 mm
MPC-300	300 x 300 mm

The height of the Cell element

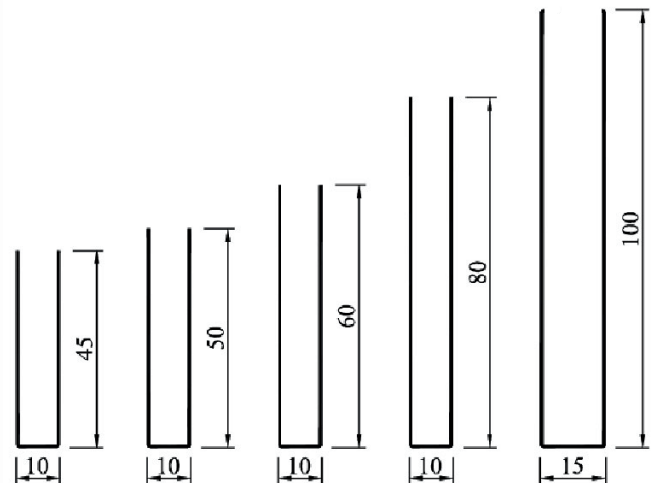

Technical Specifications

Part #	Parts Name
1. A-600	Cell Element
2. B-600	Cell Element
3. C1-600	Cross Runner
4. C2-1200	Cross Runner
5. C3-1800	Main Runner
6. C-101	Cell Ceiling Support Clip
7. CLT	Light Adapter
8. C-107	Main Runner Connector

MetaPan C panels are constructed by cell element parts ① & ②. Assembled panels fit into cross runners ③ & ④ and main runner ⑤. (see diagram below). The suspension of this system is hung by cell ceiling support clip ⑥ to the main runners on the ceiling (Fig A.) The runner connector ⑦ is used to connect the main runners (Fig B.).

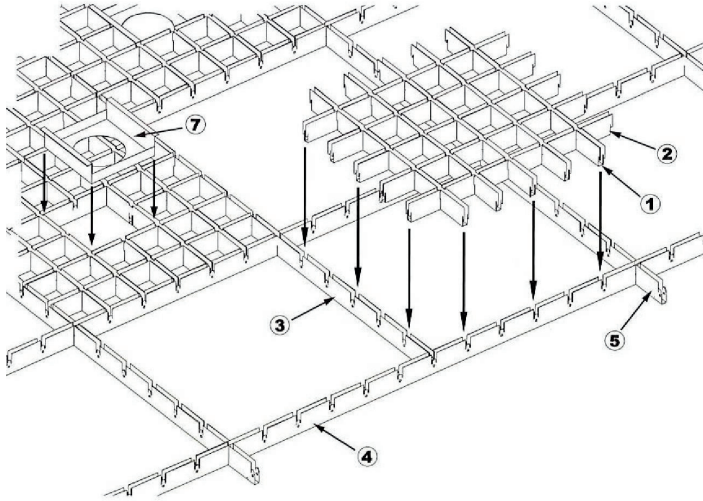

Maintenance:

Clean with damp soapy cloth, rinse with clean water and use chamois for streak free finish.

Limitations:

- For interior use only, and not in direct contact with water.
- Maximum humidity/temperature 95% R/H at 45°C.
- Back loading max. distributed load 1.0kg/m², point loads max 0.5 kg or to be independently supported.

NZ Building Act:

This product is not subject to a warning or ban under Section 26

NZ Building Code Compliance:

- B2 Durability – Clause B2.3.1 (c) (i): Asona MetaPan C with only normal maintenance will have a minimum durability of at least 5 years when installed in accordance with; manufacturer's installation requirements and AS/NZS 2785:2020.
- C3 Fire – Clause C/AS2 3.4(a): Asona MetaPan C has a Fire Material Group Number 1-S (A2-s1) by MBIE Building Performance Surface Finishes Standards Comparison 2938, 01 March 2015, in accordance with EN 13501-1:2002.

Installation:

Shall not commence until the building is watertight and dry. This product is to be installed to manufacturer's and AS/NZS 2785:2020 Standard's requirements. Seismic design may require a suitably qualified engineer. Care shall be taken when handling cell elements to avoid damage.

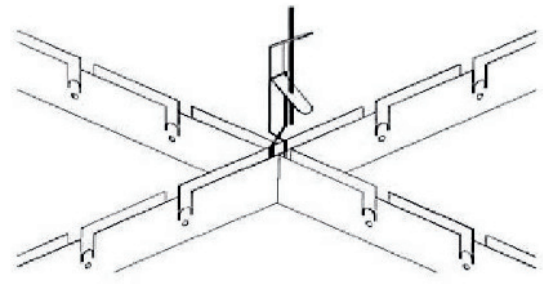

Fig A.

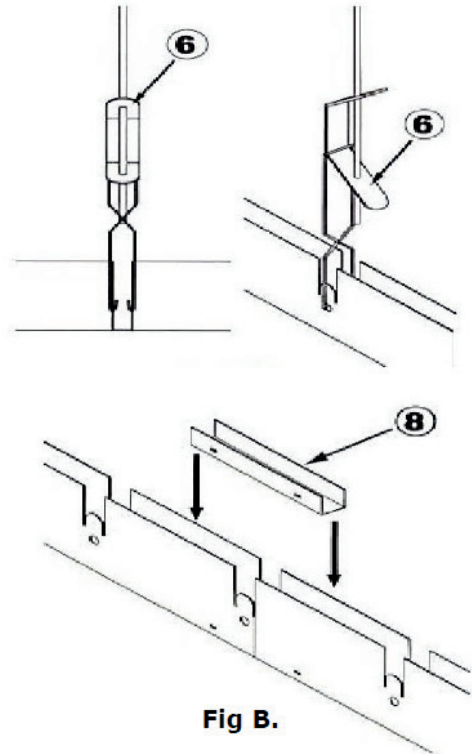

Fig B.

Warranty:

15 year limited warranty against manufacturing defects.

Specification:

Ceiling shall be MetaPan C™ open cell metal ceiling system by Asona Ltd, tel: 09 525 6575, info@asona.co.nz. Model # () , size () x ()mm, cell height ()mm, colour (). Fire Group 1-S (Asona ceiling Masterspec 5164AM specification available).